

CI-TI™ Contactors and Motor Starters

Type CI 110 - 420 EI

Description



Contactors CI 110 - 420 EI are intended for a.c. coil voltages and cover the power range 55-220 kW. The largest types, CI 210 EI-420 EI have electronic control circuits that mean low holding power and wide coil voltage ranges on both 50 and 60 Hz. The “EI” version is supplied with an integrated interface relay for PLC applications with 24V d.c. output.

Accessories include a wide selection of clip-on auxiliary contact blocks and timers. In addition, the range also includes thermal overload relays and an electronic motor protection relay for the protection of squirrel-cage motors.

Contents

Page

Description contactors CI110-420 EI	1
Ordering	2
<i>Coil voltages and coils for CI 110-180</i>	2
<i>Coil voltages and coils for CI 210-420EI</i>	2
<i>Left or right auxiliary contact block for CI 110-420 EI connectors</i>	3
<i>Accessories for CI 110-420 EI</i>	3
Description electronic motor protection relays TI 180 E and TI 630E.....	4
Ordering	4
<i>Accessories for motor protection relays TI 180 E/ 630 E</i>	4
General.....	5
Rated life.....	6
Approvals	6
Electrical life curves	7-9
General technical data TI 180E-630E	10
PTC sensor characteristic in acc. with IEC 34-11-12	11
Memory.....	11
Accuracy	11
Application as secondary relay	11
Indication	12
Setting.....	12
<i>Tripping graph, TI 80E and TI 630 E</i>	13
Connection of remote reset	13
Contact symbols and terminal markings.....	14
Main circuit.....	14
Loads	14
Tables	15-17
Control circuit.....	17
<i>Auxiliary contacts, load categories AC-15 and AC-1</i>	17
<i>Auxiliary contacts, load categories DC-12,DC-13-DC-14</i>	18
<i>Coils, consumption and operating times</i>	18
UL/CSA specifications.....	18
Dimensions.....	19-22

Ordering

Contactors CI 110-420 EI

Main circuit						Aux. contacts in base module	Code no. 1)	Type
AC-3 load			I _{th} ²⁾	I _{the} ³⁾	Main contacts (make)	1 NO + 1 NC Open Add-on options Number		
U _e 220-240 V kW	U _e 380-1000 V kW	I _e A	(AC-1) Open A	(AC-1) Encl. A	Number			
32	55	110	160	135	3	2-6	037H3081	CI 110
45	75	140	250	210	3	2-6	037H3339	CI 141
55	90	180	250	210	3	2-6	037H3082	CI 180
63	110	210	350	300	3	2-6	037H3259	CI 210 EI
80	132	250	350	300	3	2-6	037H3267	CI 250 EI
90	160	300	450	380	3	2-6	037H3269	CI 300 EI
132	220	420	500	425	3	2-6	037H3279	CI 420 EI

1) Coil voltage/frequency or Suffix no. (see table below) must be added to the Danfoss code no.

2) The thermal current value I_{th} gives the maximum load at 40°C, which corresponds to installing the contactor in air (open).

3) The thermal current value I_{the} gives the maximum load at 60°C, corresponding to installing the contactor inside an enclosure.

Coil voltages and coils for CI 110-180

Coil voltage*	Suffix no.	Code no.
110 V, 50 Hz / 120 V, 60 Hz	22	037H3261
220-230 V, 50 Hz / 240 V, 60 Hz	31	037H3262
240 V, 50 Hz / 277 V, 60 Hz	33	037H3263
380-400 V, 50 Hz / 440, 60 Hz	37	037H3264

* Standard voltage tolerance -15%, +10%

Coil voltages and coils for CI 210-420 EI

Coil voltage*	Suffix no.	Coils for CI 210EI-300 EI	Coils for CI 420 EI
110-130 V, 50/60 Hz	23	037H3413	037H3421
208-277 V, 50/60 Hz	32	037H3415	037H3423
380-440 V, 50/60 Hz	39	037H3417	037H3425

* Standard voltage tolerance -15% +10%

Correct ordering of contactors

Example: CI 210EI for 230 V, 50 Hz coil voltage.

Select one of the following two forms of ordering:

1. Danfoss code no. + Suffix no.: 037H3259.32
or
2. Danfoss code no. + coil voltage/frequency:
037H3259, 230 V/50 Hz



CBC-11
Auxiliary contact block

Left or right auxiliary contact block CBC for CI 110-420 EI contactors

Contact function	Load				Code no.	Type
	I _e (AC - 15) A	I _{th} ²⁾ (AC-1) Open A	I _{the} ³⁾ (AC-1) Encl. A	U _e V		
1 NO+1NC inside mounting	5.5	16	12	690	037H3358	CBC-11 ¹⁾
1 NO+1NC outside mounting	5.5	16	12	690	037H3348	CBC-11 ¹⁾

¹⁾ Force-actuated contacts suitable for safety switching.
²⁾ The thermal current value I_{th} gives the maximum load at 40°C, which corresponds to installing the contactor in air (open).
³⁾ The thermal current value I_{the} gives the maximum load at 60°C, corresponding to installing the contactor inside an enclosure.



Mechanical interlock



RCC-/VRC-
RC Element / varistor element

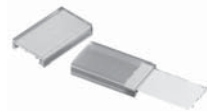

Marking plate



Terminal block for CI 110-420 EI



Terminal cover for CI 110-420 EI

Accessories for contactors CI 110-420 EI

Description	Comments	Code no.
Mech. interlock for CI 110-420 EI	Mech. interlock can be established between pairs	037H3232
RC Element for CI 110-180	Reduces overvoltage on de-energization of coils Type RCC 240 (190-240 V, 50 Hz/220-277V, 60 Hz)	037H3236
VRC-Varistor Element for CI 110-180	Reduces overvoltage on de-energization of coils Type VRC 136 (56-136 V, a.c.) Type VRC 277 (137-277 V, a.c.) Type VRC 575 (278-575 V, a.c.)	037H3399 037H3407 037H3241
UL-terminals	For CI 110, type CI 110 HU (set of 3) For CI 141, CI 180 type CI 180 HU (set of 3)	037H3240 037H3249
Terminal cover	Finger protection of terminals: Transparent cover for CI 110 (set of 2) Transparent cover CI 141, CI 180 (set of 2) Transparent cover CI 210 EI-420 EI (set of 2) Terminal block for CI 110 (set of 2) Terminal block for CI 141, CI 180 (set of 2) Terminal block for CI 210 EI-420 EI (set of 2)	037H3246 037H3409 037H3406 037H3244 037H3247 037H3404
Clip-on markers for CI 4 and CI 110...420 EI	Rating plate with cover (100-off)	037H3142
Main contact set for CI 110-420 EI	Contact set (complete) for CI 110 Contact set (complete) for CI 141 Contact set (complete) for CI 180 Contact set (complete) for CI 210 EI Contact set (complete) for CI 250 EI Contact set (complete) for CI 300 EI Contact set (complete) for CI 420 EI	037H3418 037H3357 037H3419 037H3400 037H3401 037H3402 037H3403

Description

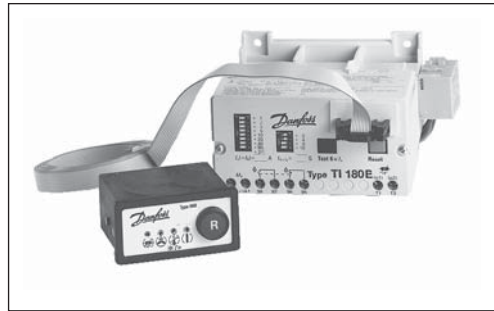

TI 180 E and TI 630

Electronic motor protection relays TI 180 E and TI 630E give effective protection of electric motors exposed to thermal overload, phase failure and asymmetrical load. They therefore fulfil the requirements of IEC 947-4 and IEC 255-8. TI 180 E/630 E are compact units with built-in current transformers for the measurement of motor operating current.

Features

- Trip range 20-180 A, that can be reduced by loop to 2.5-5 A or less.
- Trip range from 160-630 A
- Galvanically isolated signal contact.
- Light emitting diodes for operating and protection functions.
- Connection for thermistor over temperature protection.
- TI 180 E can be mounted on backplate, 35 mm symmetrical DIN rail or direct on contactors CI 110-180 via bus bars.
- Test and reset functions

Ordering



Current rail set for CI 110-180



Front cover for TI 180 E



RRM
Remote reset module for TI 180 E

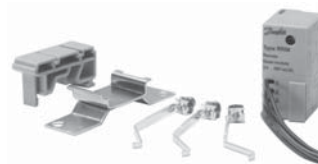

RRM
Remote reset module for TI 630 E



IMR
Indication module for TI 180 E, 630 E

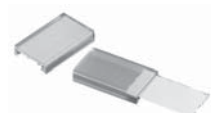

Marking plate for TI 630 E

Electronic motor protection relay TI 180 E and TI 630 E

Control voltage U _s	Range D.O.L.	Manual reset Code no.	Type
24 V, 50/60 Hz	20-180 A	047H3013	TI 180 E
110 V, 50/60 Hz		047H3014	
220-230 V, 50/60 Hz		047H3015	
240 V, 50/60 Hz		047H3016	
380-400 V, 50/60 Hz		047H3017	
415 V, 50/60 Hz		047H3018	
24 V, 50/60 Hz	160-630 A	047H3031	TI 630 E
110 V, 50/60 Hz		047H3032	
220-230 V, 50/60 Hz		047H3033	
240 V, 50/60 Hz		047H3034	
380-400 V, 50/60 Hz		047H3035	
415 V, 50/60 Hz		047H3036	

With Y/D start, the motor full load current must be multiplied by 0.58

Accessories for motor protection relays TI 180 E-630 E

Description	Comments	Code no.
Current rail set	For direct mounting of motor protection relay TI 180 E on contactors CI 110 (set of 3)	047H3027
	For direct mounting of motor protection relay TI 180 E on contactors CI 141-180 (set of 3)	047H3028
Cover	Front cover for motor protection relay TI 180 E (prevents tampering with settings on front)	047H3025
	Finger protection of main terminals on TI 180 E and CI 110 (set of 2)	037H3246
	Finger protection of main terminals on TI 180 E and CI 141-180 (set of 2)	037H3409
	Finger protection of main terminals on TI 630 E and CI 210 EI-420 EI (set of 2)	037H3406
Indication module type IMR for TI 180 E, 630 E	Indication and reset module for panel mounting (IP 54 from front). Inclusive 3 m connection cable, plugs and mounting fixture.	047H3023
Remote reset module type RRM	For TI 180 E and TI 630 E	047H3024
DIN rail socket for RRM	Used with TI 630 E and RM	037H3154
Mounting plate for RRM		047H3120
Marking plate	Marking plate with covers for TI 630 E (100 off)	037H3142

General

Contactors, thermal overload relays and accessories are designed and tested in acc. w. IEC 947/EN 60947.

Pulse voltage

Type	U _{imp}
CI 110-420 EI	12 kV

Environment

Temperate climate
 Tested and passed in acc. w. DIN 50 016 and 40 046 part 38 and IEC 68
 Max. installation height: 2000 NN, in acc. w. IEC 947

Ambient temperature

Type	Ambient temperature	
	Operation	Storage/Transport
CI 110 - CI 420 EI	-25 °C ... +60 °C	-40 °C ... +80 °C

Vibration

Tested and passed in accordance with IEC 68-2-6

Type	Vibration ¹⁾
CI 110 - 420 EI	2 g, 10-150 Hz

¹⁾ Operating conditions: All directions with de-energized coil.

Short circuit protection of contactors without thermal overload relay
 Max. fuse type gG at 3 x 380-690 V

Contactor type	Short circuit co-ordinator type 1 A	Short circuit co-ordinator type 2 A
CI 110	250	200
CI 141	315	250
CI 180	355	315
CI 210 EI-250 EI	500	400
CI 300 EI-420 EI	630	500

Mounting direction

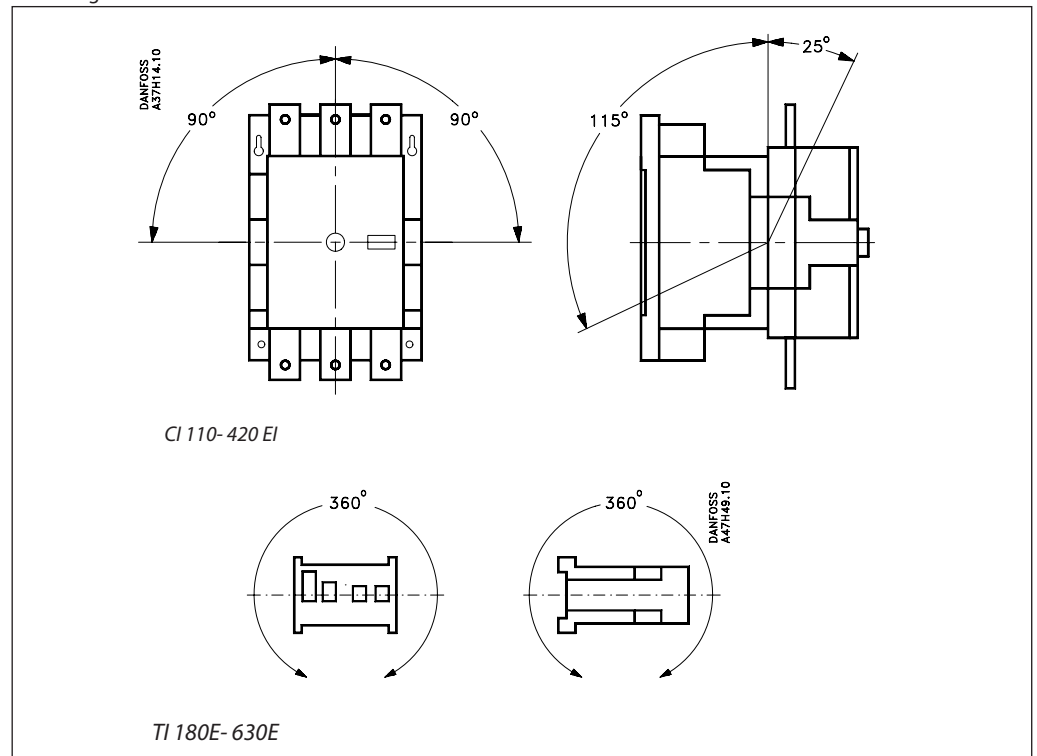

Rated life

Type	Mechanical life Operations	Electrical life AC-3 load Operations	Switching per hour AC-3 load Operations
CI 110-420 EI	10 x 10 ⁶	1 x 10 ⁶	200

Approvals

Approval authority / Product type	CE EN 60947	A CSA Canada	S UL-listed USA	Lloyds Register of Shipping, UK	Germanischer Lloyd, Germany	Bureau Veritas France	PTB
CI 110	●	●	●	●	●	●	□
CI 141	●	●	●	●	●	●	□
CI 180	●	●	●	●	●	●	□
CI 210 EI	●	●	●	●	●	●	□
CI 250 EI	●	●	●	●	●	●	□
CI 300 EI	●	●	●	●	●	●	□
CI 420 EI	●	●	●	●	●	●	□
CBC-	●	●	●	●	●	●	□
RCC-	●	●	●	○	○	○	□
TI 180 E	●	●	●	●	□	●	●
TI 630 E	●	●	●	●	●	●	●

- Approved
- No approval requirement
- No approval applied for

Electrical life curve

Contactors CI 110, CI 141, CI 180, CI 210 EI/250 EI/300 EI/420 EI load categories AC-1, AC-3

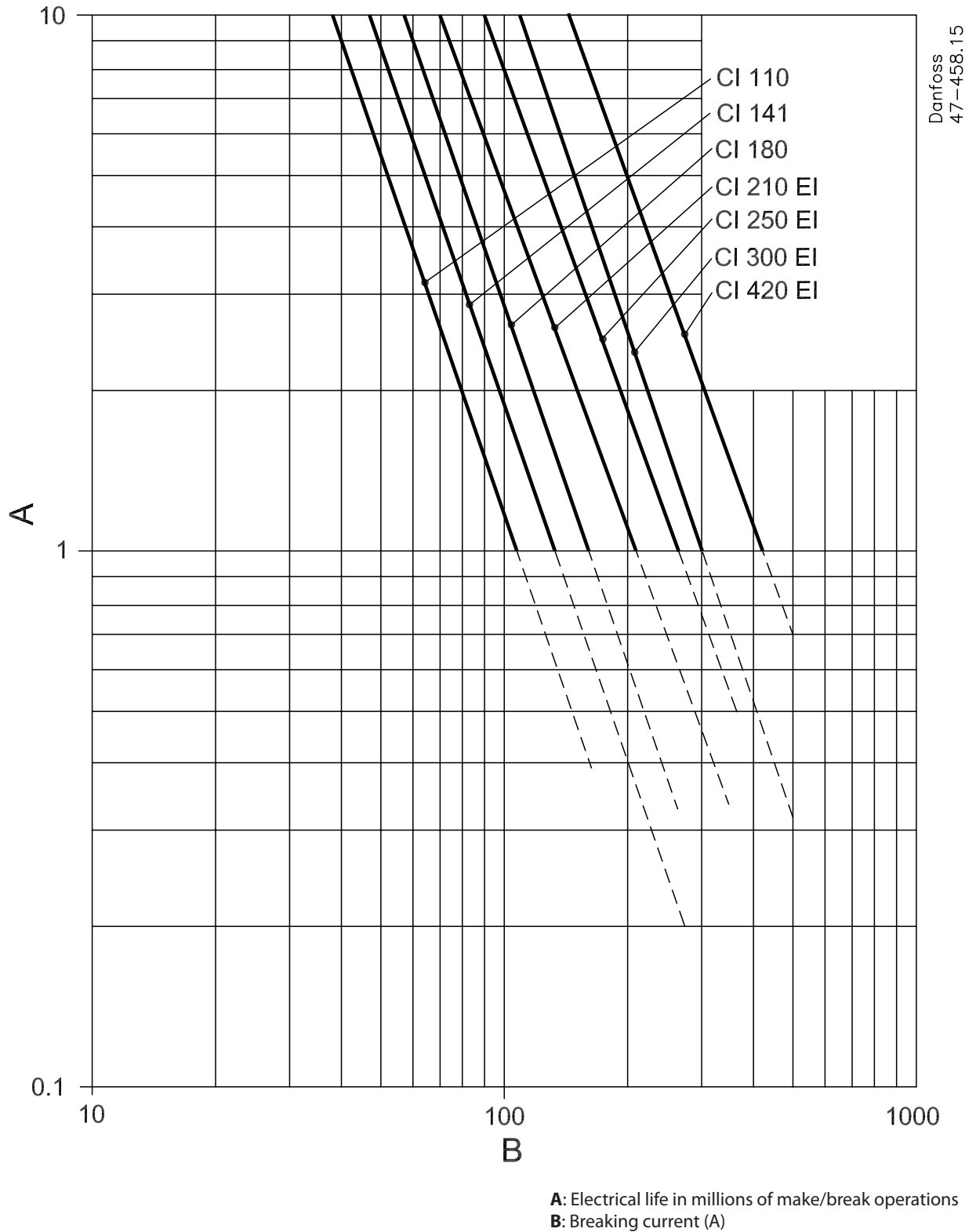

Electrical life curve

Contactors CI 110, CI 141, CI 180, CI 210 EI/250 EI/300 EI/420 EI load categories 90% AC-3, 10% AC-4

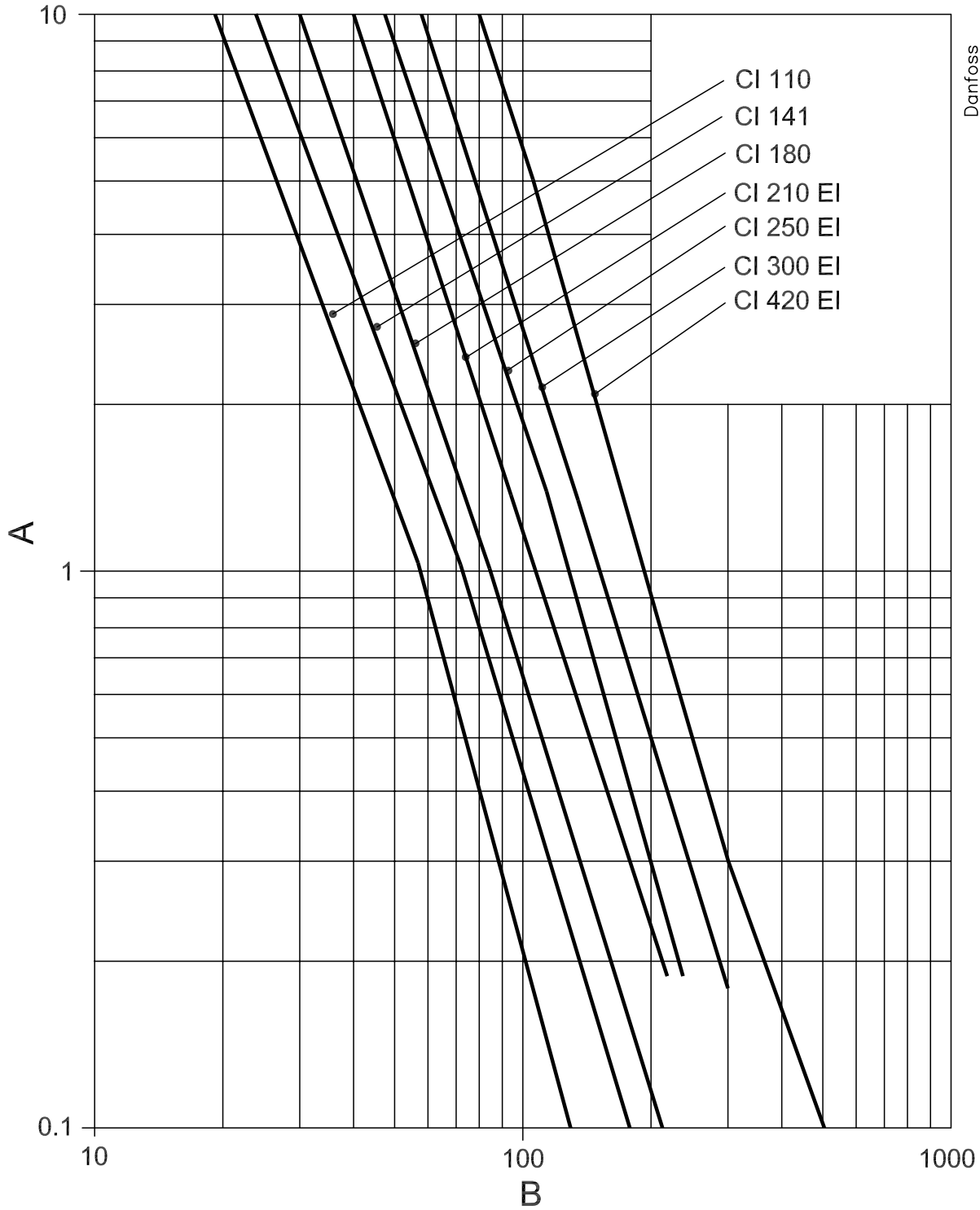

Danfoss
47-460.15

A: Electrical life in millions of make/break operations
B: Breaking current (A)

Electrical life curve

Contactors CI 110, CI 141, CI 180, CI 210 EI/250 EI/300 EI/420 EI load category AC-4

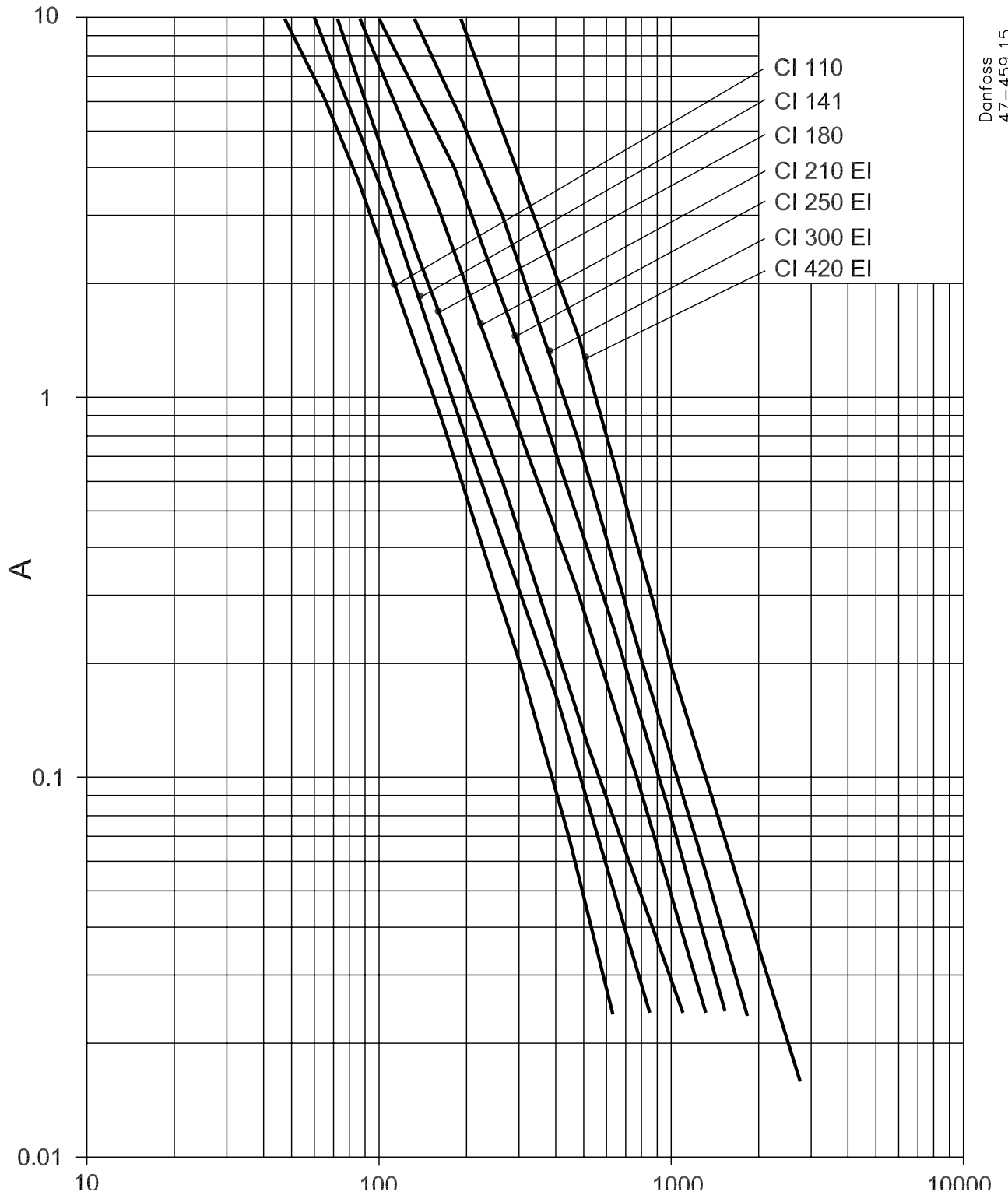

Danfoss
47-459.15

A: Electrical life in millions of make/break operations
B: Breaking current (A)

TI 180 E - 630 E

Nominal voltage	Main circuit	IEC, BS, AS, SEV, VDE 0660 1000 V						
	Control circuit	CSA, UL		600 V				
		IEC 255-8		440 V				
		SEV		380 V				
		BS, AS, VDE 0660		250 V				
CSA, UL		240 V						
Test voltage	Main circuit	IEC 947-4		3.5 kV a.c. for 1 min.,				
	Control circuit	IEC 947-5		2.5 kV a.c. for 1 min.,				
Pulse voltage	IEC 255-4 SEN 361503	5 kV, 1.2/50 μ s						
Noise voltage	ANSI/C37.90a 1971 IEC 255-6 SEN 361503	2.5 kV, 1 MHz, 2 s						
Setting range	TI 180 E	20-180 A						
	TI 630 E	160-630 A						
Supply	Control circuit	50-60 Hz	24 V	110V	220-230 V	240 V	380-400 V	415 V
Voltage tolerance	a.c.:	0.8-1.1 x U _s , 50/60 Hz						
	d.c.:	0.9-1.2 U _s						
Consumption	a.c.:	2.5 VA/ 2 W						
	d.c.:	2 W						
Max. power loss	Measuring current circuit and supply	a.c.: 4.5 VA/ 4 W						
		d.c.: 4 W						
Remote reset	External resistance	110-230 V:		8.2 k Ω , 4 W				
		240-440 V:		22 k Ω , 10 W				
Max. fuse	TI 180E and TI 630E are short-circuit proof. Fuse size depends on contactor selection. See page 5							
Ambient temperature	Operation	-5 \rightarrow + 60 $^{\circ}$ C						
	Intermittent operation	-20 \rightarrow + 70 $^{\circ}$ C						
	Transport	-50 \rightarrow + 85 $^{\circ}$ C						
	Storage	-50 \rightarrow + 60 $^{\circ}$ C						
Weather resistance	Temp./Relative humidity	40 $^{\circ}$ C, 92% RH i 56 dg.						
	Temperature climate	23 $^{\circ}$ C, 83% RH/ 40 $^{\circ}$ C, 93% RH						
Vibration	IEC 68	3 g, 10-150 Hz						
Shock	IEC 68-2-27/ DIN 40046/7	30 g, shock pulse 11 ms, half-sinusoidal, in 3 directions (x, y, z)						
No. of contacts	Control circuit	1 NO + 1 NC, galv. isolated						
Output relay	Operating voltage [V]	24	48	60	110-(125)	220-250	380 - 415	440
	I _{th} [A]	4	4	4	4	4	4	4
	AC-15, cos ϕ = 0.3 [A]	3	3	3	3	3	1.2	1.2
	DC-13, L/R = 35 ms [A]	2	2	2	2, (0,3)	0.2	-	-
Max. control of current fuse	Type gG	10 A, 500 V						
	Type BS 88 type T	16 A, 250 V						
Connection	Control circuit	single core:		2 x 0.75 mm ² ...2 x 2.5 mm ²				
		with core sieve:		2 x 0.75 mm ² ...2 x 1.5 mm ²				
	Main circuit	4...95 mm ²						
Thermistor overtemperature protection	Max. PTC resistance value in circuit (cold condition)	1.5 k Ω						
	Max. no. of PTC resistors (acc. to IEC 34-11-2)	6						
	Activation value	v _A = -20...+70 $^{\circ}$ C		3.3 k Ω				
	Reset value	v _A = -20...+70 $^{\circ}$ C		1.8 k Ω				
	Activation value on short-circuit in sensor circuit	v _A = -20...+70 $^{\circ}$ C \leq 15 Ω						
	Cross section [mm ²]	0.5	0.75	1	1.5	2.5		
	Max. cable length [m]	200	300	400	600	1000		
								Up to 100 m, screened cable not necessary

PTC sensor characteristic in accordance with IEC 34-11-12

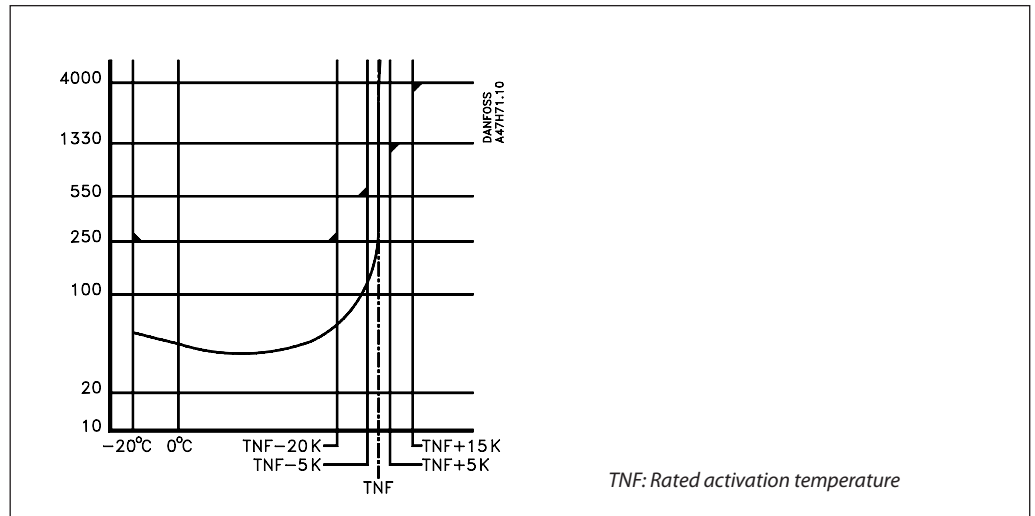

Memory

On voltage drop-out, the thermal overload relay remembers its condition (e.g. thermal cut-out) for a period. When supply voltage is restored, the associated LED lights up.

Memory period	at 25°C	approx. 30 min
	at 60°C	approx. 5 min
	at 70°C	approx. 1 min

Accuracy

Parameter	Comments	Tolerance
Release range	TI 180 E: 20-180 A, changeable to 2.5-5 A	Function range: 1.05-1.15 I _e incl. tolerance
	TI 630 E: 160-630 A	
Release time	2-30 s in steps of 2 s	Setting: 2 ... 6 s ± 0.5 s, from 8 ... 30 s ± 10%
Overload indication	LED flash for thermal overload	Setting: 110% × I _e ± 2%
Phase drop-out (differential protection)	Release times	Start: 1.5 s ± 0.5 s.
		Operation: 3 s ± 1 s
Asymmetry	Standard versions : 40%	Option: 20% or 60%
Test function	Setting time (t _s × I _e)	± 20%
Reset time	Cool-off time (6 x set time)	

Application as secondary relay



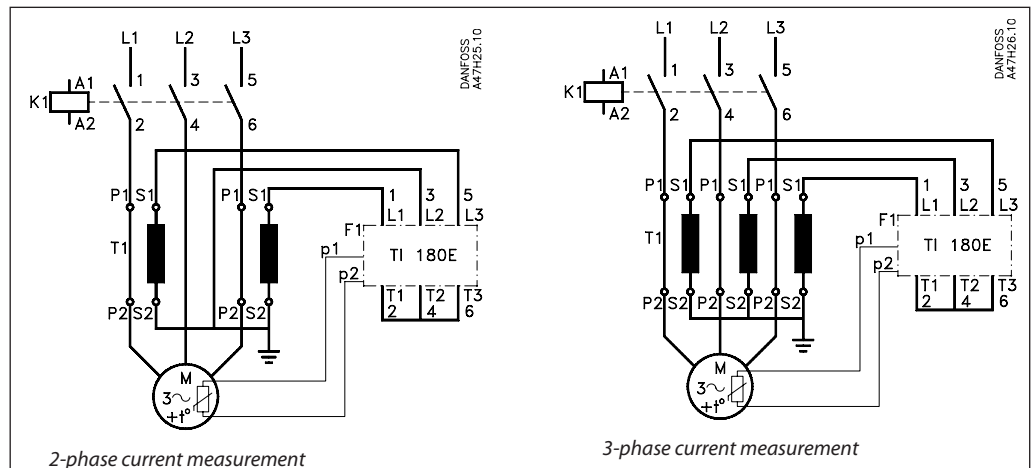

Used as a secondary relay, TI 180 E can also protect motors with full load currents higher than 180 A, and high-voltage motors for operating voltages higher than 1000 V.

Recommended current transformer data:
 Min. operating voltage = rated motor operating voltage
 Min. primary current = motor operating current
 Class and overcurrent factor: 5 P 10

Secondary current	No. of windings	Rated current setting
5 A	8	20-40 = (2.5-5) × 8
1 A	40	20-40 = (0.5-1) × 40



Indication

 <p>Operationally ready The green LED lights up when supply voltage is on. It goes out in the event of cut-out and voltage failure. The cause of cut-out is remembered up to 30 min after voltage failure.</p>	 <p>Asymmetric load On phase failure or more than 40% phase current asymmetry, the thermal overload relay cuts out - on starting within 1.5 s and during operation within 3 s. The cut-out condition is indicated by the red LED.</p>
 <p>Thermal overload If the current setting is exceeded by 110%, the red LED flashes.</p>  <p>If the overload period exceeds the set release time, the thermal overload relay cuts out and the red LED lights up constantly.</p>	<p>Thermistor overtemperature Thermistor overtemperature protection is used for motors with PTC sensors built into the windings. If PTC temperature sensors are connected, the resistors across terminals T1-T2 must be removed. If the permissible motor temperature is exceeded, or if the thermistor circuit is broken, the motor is cut out and the LED lights up.</p>

Setting

TI 180 E

OFF	ON	
<input type="checkbox"/>	<input type="checkbox"/>	+ 1
<input type="checkbox"/>	<input type="checkbox"/>	+ 2
<input type="checkbox"/>	<input type="checkbox"/>	+ 3
<input type="checkbox"/>	<input type="checkbox"/>	+ 5
<input type="checkbox"/>	<input type="checkbox"/>	+10
<input type="checkbox"/>	<input type="checkbox"/>	+20
<input type="checkbox"/>	<input type="checkbox"/>	+40
<input type="checkbox"/>	<input type="checkbox"/>	+80
<input type="checkbox"/>	<input type="checkbox"/>	+20
		$I_e (=I_B) = 120A$

TI 180 E

Example 1

OFF	ON	
<input type="checkbox"/>	<input type="checkbox"/>	+ 2
<input type="checkbox"/>	<input type="checkbox"/>	+ 4
<input type="checkbox"/>	<input type="checkbox"/>	+ 8
<input type="checkbox"/>	<input type="checkbox"/>	+16
<input type="checkbox"/>	<input type="checkbox"/>	+30
<input type="checkbox"/>	<input type="checkbox"/>	+60
<input type="checkbox"/>	<input type="checkbox"/>	+120
<input type="checkbox"/>	<input type="checkbox"/>	+230
<input type="checkbox"/>	<input type="checkbox"/>	+160
		$I_e (=I_B) = 580A$

TI 630 E

The operating current can be set with the eight slide switches.

TI 180 E
Motor full load current 120 A
Setting: Basic value 20 + 80 + 20 = 120 A

TI 630 E
Motor full load current 580 A
Setting: Basic value 160 + 2 + 8 + 60 + 120 + 230 = 580A

Setting from 2.5 A to 20 A

$$I_e \times \text{no. of motor lead windings}$$

Motor full load current: 8.7 A
No. of motor lead windings: 4
Thermal overload relay setting: $(8.7 \times 4) = 34.8$
(Basic value 20 + 10 + 5) = 35 A

With star-delta start, the motor full load current must be multiplied by a factor of 0.58.
The thermal overload relay setting is $I_e \times 0.58$.

OFF	ON	
<input type="checkbox"/>	<input type="checkbox"/>	+ 1
<input type="checkbox"/>	<input type="checkbox"/>	+ 2
<input type="checkbox"/>	<input type="checkbox"/>	+ 3
<input type="checkbox"/>	<input type="checkbox"/>	+ 5
<input type="checkbox"/>	<input type="checkbox"/>	+10
<input type="checkbox"/>	<input type="checkbox"/>	+20
<input type="checkbox"/>	<input type="checkbox"/>	+40
<input type="checkbox"/>	<input type="checkbox"/>	+80
<input type="checkbox"/>	<input type="checkbox"/>	+20
		$I_e (=I_B) = 35A$

Motor lead wound 2 times

Motor lead wound 4 times

Example 2

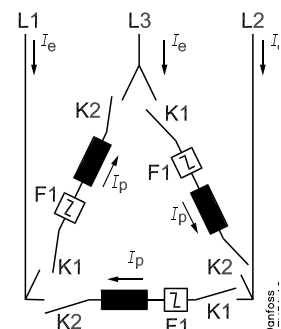

Tripping graph, TI 180 E and TI 630 EI

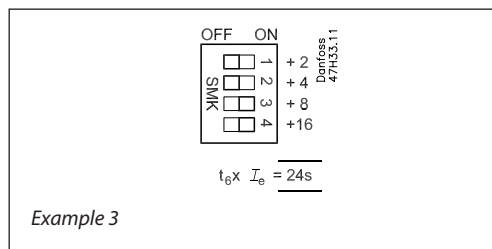
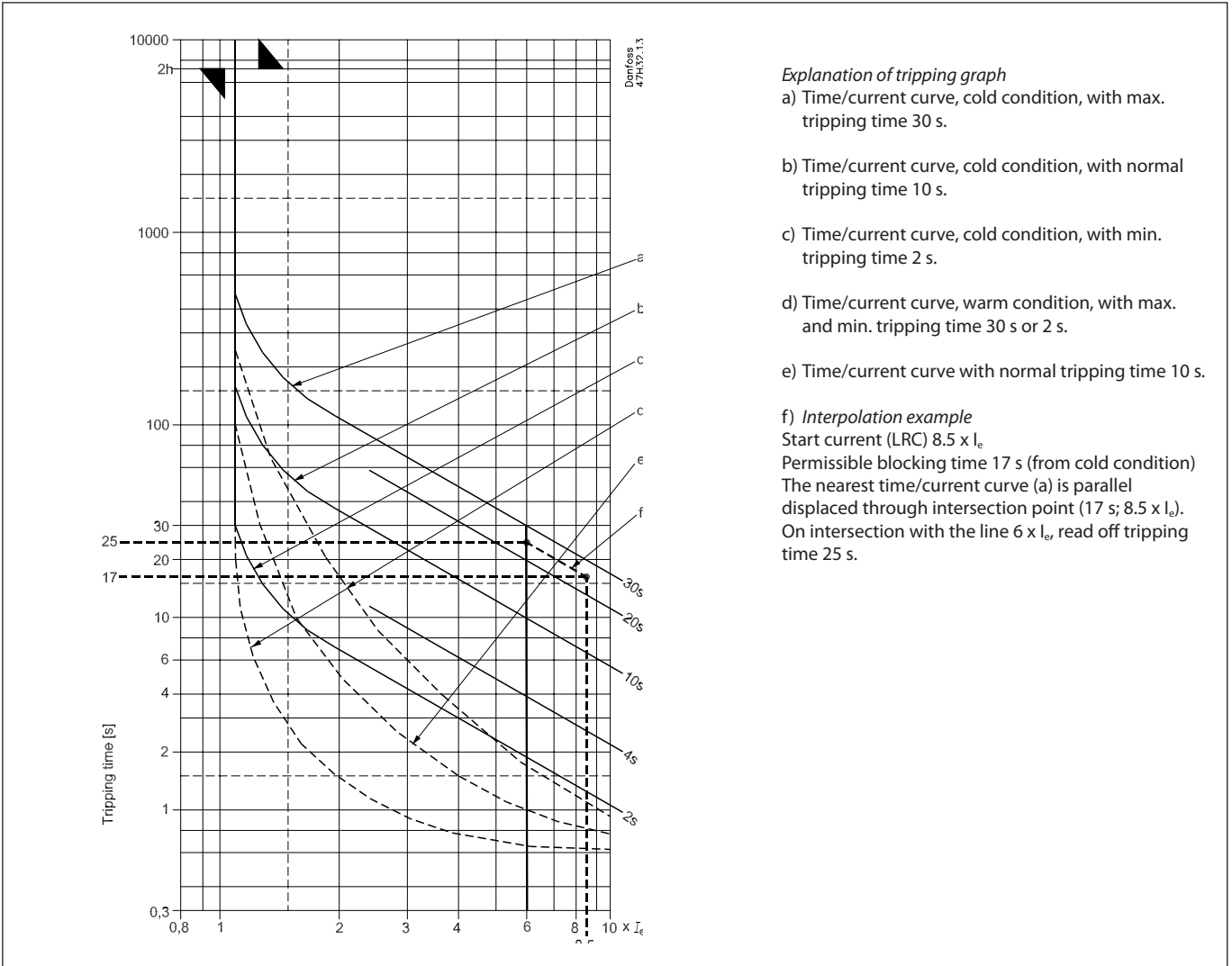

The thermal overload relay must be set on the nearest lower value, i.e. 24 s.

Connection of remote reset

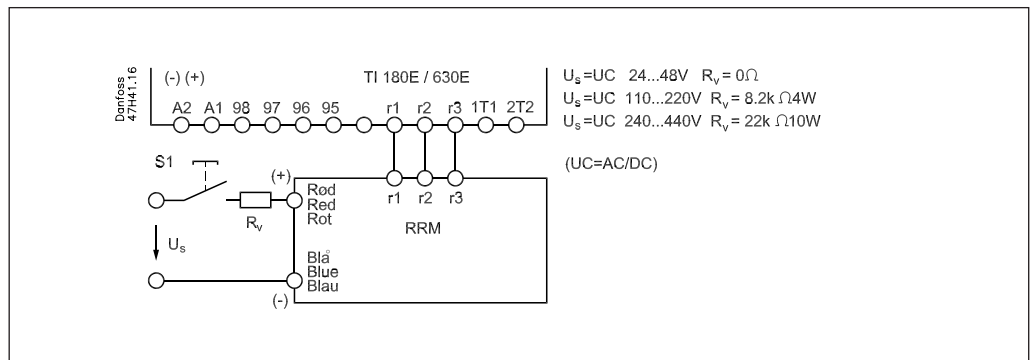

Contact symbols and terminal markings

Auxiliary contacts

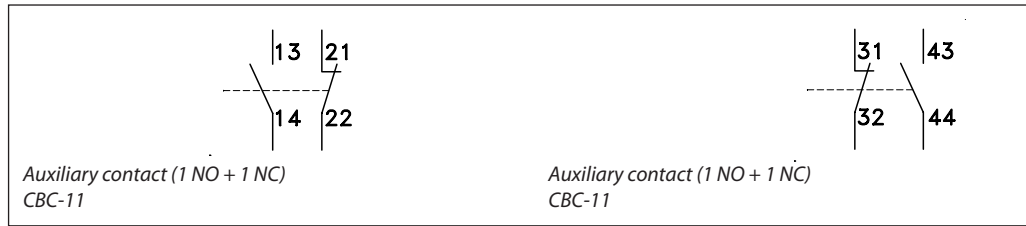

Contactors

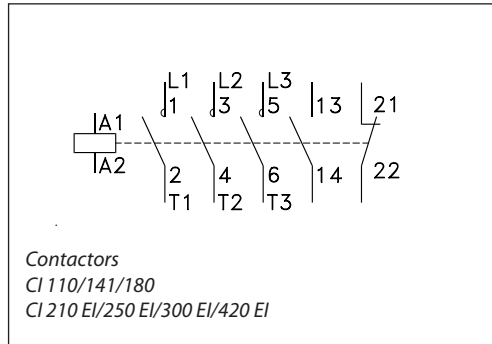

Main circuit

Connections, main contacts

Type	Connection method	Single core [mm ²]	Multi core		Recommended Tightening torque [Nm]
			without terminal sleeve [mm ²]	with terminal sleeve [mm ²]	
CI 110	Screw and lug	16 - 95	16 - 95	-	8 - 10
	Terminal block	16 - 95	16 - 70	-	8 - 10
CI 141, CI 180	Screw and lug	25 - 120	25 - 120	-	10 - 12
	Terminal block	25 - 120	25 - 95	-	10 - 12
CI 210 EI, CI 250 EI, CI 300 EI, CI 420 EI	Screw and lug	25 - 300	25 - 300	-	16
	Terminal block	25 - 300	25 - 240	-	15 - 20

Loads

Direct start, load categories AC-2, AC-3

Type		Rated loads at 50-60 Hz						
		220-230 V	240 V	380-400 V	415 V	500 V	690 V	1000 V
CI 110	A	110	110	110	130 ¹⁾	110	110	40
	kW	34	36	61	75 ¹⁾	76	106	55
CI 141	A	140	140	140	155 ¹⁾	115	115	55
	kW	45	47	78	90 ¹⁾	98	135	75
CI 180	A	180	180	180	189 ¹⁾	170	170	65
	kW	57	60	101	110 ¹⁾	98	135	90
CI 210 EI	A	210	210	210	227 ¹⁾	210	210	30
	kW	67	70	118	132 ¹⁾	147	205	110
CI 250 EI	A	250	250	250	258 ¹⁾	250	250	95
	kW	80	83	140	150 ¹⁾	177	250	132
CI 300 EI	A	300	300	300	315 ¹⁾	300	300	115
	kW	97	101	170	185 ¹⁾	213	293	160
CI 420 EI	A	420	420	420	420	360	360	160
	kW	135	141	238	250	298	424	225

¹⁾ Typical electrical life time –25%

Table (continued)

Star-delta start, load categories AC-2, AC-3

Type		Rated loads at 50-60 Hz						
		220-230 V	240 V	380-400 V	415 V	500 V	690 V	1000 V
CI 110	A	191	191	191	191	191	191	69
	kW	55	63	100	100	132	160	90
CI 141	A	242	242	242	242	199	199	95
	kW	75	80	132	132	132	200	132
CI 180	A	312	312	312	312	312	312	113
	kW	90	100	160	160	200	300	160
CI 210 EI	A	364	364	364	364	364	364	139
	kW	110	125	200	220	250	355	200
CI 250 EI	A	433	433	433	433	433	433	165
	kW	132	150	250	250	315	425	220
CI 300 EI	A	520	520	520	520	520	520	200
	kW	160	160	300	315	375	530	280
CI 420 EI	A	727	727	727	727	727	727	277
	kW	220	250	425	425	530	750	400

Three phase ohmic load, load category AC-1

Type		Operating temperature max. 40 °C (Open condition)						
		220-230 V	240 V	380-400 V	415 V	500 V	690 V	1000 V
CI 110	A	160	160	160	160	160	160	160
	kW	64	67	111	115	139	191	277
CI 141/CI 180	A	250	250	250	250	250	250	250
	kW	100	104	173	180	217	299	433
CI 210 EI/CI 250 EI	A	350	350	350	350	350	350	350
	kW	139	145	242	252	303	418	606
CI 300 EI	A	450	450	450	450	450	450	450
	kW	179	187	312	323	390	538	779
CI 420 EI	A	500	500	500	500	500	500	500
	kW	199	208	346	359	433	598	866

Three phase ohmic load, load category AC-1

Type		Operating temperature max. 60 °C (Enclosed condition)						
		220-230 V	240 V	380-400 V	415 V	500 V	690 V	1000 V
CI 110	A	135	135	135	135	135	135	135
	kW	54	56	94	97	117	161	234
CI 141/CI 180	A	210	210	210	210	210	210	210
	kW	84	87	145	151	182	251	364
CI 210 EI/CI 250 EI	A	300	300	300	300	300	300	300
	kW	120	125	208	216	260	359	520
CI 300 EI	A	380	380	380	380	380	380	380
	kW	151	158	263	273	329	454	658
CI 420 EI	A	425	425	425	425	425	425	425
	kW	169	177	294	305	368	508	736

Switching three phase power transformers (AC-6a)

Type		Transformer load, (factor n = 30, inrush current = n x rated transformer current)						
		220-230 V	240 V	380-400 V	415 V	500 V	690 V	1000 V
CI 110	A	60	60	60	60	60	60	60
	kVA	24	25	42	43	52	72	104
CI 141	A	70	70	70	70	70	70	70
	kVA	28	29	48	50	61	84	121
CI 180	A	85	85	85	85	85	85	85
	kVA	34	35	59	61	74	102	147
CI 210 EI	A	105	105	105	105	105	105	105
	kVA	42	44	73	75	91	125	182
CI 250 EI	A	125	125	125	125	125	125	125
	kVA	50	52	87	90	108	149	217
CI 300 EI	A	150	150	150	150	150	150	150
	kVA	60	62	104	108	130	179	260
CI 420 EI	A	210	210	210	210	210	210	210
	kVA	84	87	145	151	182	250	364

Table (continued)

Switching lighting

Type	Incandescent lamps	Fluorescent lamps, individually compensated	
		Max. operat. current [A] at operat. temperature ¹⁾	
	A	40 °C	60 °C
CI 110	120	144	122
CI 141	140	225	189
CI 180	170	225	189
CI 210 EI/250 EI	273	315	270
CI 300 EI	300	405	342
CI 420 EI	420	450	383

¹⁾ 40°C is defined as non-enclosed installation
60°C is defined as enclosed installation

Switching capacitor loads, individual capacitors (AC-6b)

Inductance in leads between capacitors connected in parallel min. 6 µH.

Type	Max. reactive power [kVAR]									
	220-240 V		380-415 V		500 V		690 V		1000 V	
	40 °C	60 °C	40 °C	60 °C	40 °C	60 °C	40 °C	60 °C	40 °C	60 °C
CI 110	45	38	48	65	97	82	134	113	194	164
CI 141	70	59	121	102	152	127	209	176	303	255
CI 180	70	59	121	102	152	127	209	176	303	255

¹⁾ 40°C is defined as non-enclosed installation
60°C is defined as enclosed installation

Switching capacitor loads, regulating capacitors (ac-6b)

Inductance in leads between parallel-connected capacitors must be min. 6 µH

Type	Max. reactive power [kVAR]									
	220-240 V		380-415 V		500 V		690 V			
	40 °C	60 °C	40 °C	60 °C	40 °C	60 °C	40 °C	60 °C	40 °C	60 °C
CI 110	45	38	56	56	56	56	57	57		
CI 141	70	59	76	76	76	76	78	78		
CI 180	70	59	111	102	113	113	114	114		

¹⁾ 40°C is defined as non-enclosed installation
60°C is defined as enclosed installation

Switching direct current load

Load categories DC-3 and DC-5, contacts connected in series

Type	Max. operating current [A]									
	DC-3, 3-pole in series					DC-5, 3-pole in series				
	24 V	48 V	110 V	220 V	440 V	24 V	48 V	110 V	220 V	440 V
CI 110	135	135	135	135	3	135	135	135	135	1.2
CI 141/ 180	210	210	210	210	3.5	210	210	210	210	2.1

¹⁾ 40°C is defined as non-enclosed installation
60°C is defined as enclosed installation

Switching direct current load

Load category DC-1, contacts connected in series

Type	Max. operating current [A]														
	24 V			48 V			110 V			220 V			440 V		
	1-pole	2-pole	3-pole	1-pole	2-pole	3-pole	1-pole	2-pole	3-pole	1-pole	2-pole	3-pole	1-pole	2-pole	3-pole
CI 110	135	135	135	135	135	135	135	135	135	3	135	120	0.6	3	11
CI 141/ 180	210	210	210	210	210	210	210	210	210	3.3	210	210	0.75	3.3	11

Table (continued)

Contact resistance and power losses

Type	Typical impedance per pole mΩ	Power losses all 3 poles		Coil consumption a.c. W	Total power losses	
		AC-3 W	AC-1 W		AC-3 W	AC-1 W
CI 110	0.4	13.2	31	9.5	22.7	40.5
CI 141	0.42	24.6	79	7.0	31.6	86.0
CI 180	0.42	36.3	79	7.0	43.3	86.0
CI 210 EI	0.22	29.4	81	7.0	36.4	88.0
CI 250 EI	0.22	41.7	81	7.0	48.7	88.0
CI 300 EI	0.18	48.6	109	7.0	55.6	116.0
CI 420 EI	0.15	79.5	112.5	7.0	86.5	119.5

Short time withstand current I_{cw}

Type	Current transfer time in sec.							Min. cooling in min.
	1	4	10	15	60	240	900	
	Short time withstand in Amps (I_{cw})							
CI 110	1800	1500	1040	860	650	340	240	20
CI 141	2550	1970	1240	1130	850	600	440	20
CI 180	2550	1970	1360	1130	850	600	440	20
CI 210 EI	3405	3150	2360	2000	1215	705	460	20
CI 250 EI	3870	3870	2570	2110	1300	750	500	20
CI 300 EI	4727	4100	2840	2270	1500	840	590	20
CI 420 EI	6375	6375	4700	3460	1820	1280	840	20

Control circuit

Connections, auxiliary contacts

Type	Connection method	Single and multi core [mm ²]	High capacity		Tightening torque [Nm]
			without terminal sleeve [mm ²]	with terminal sleeve [mm ²]	
Coil terminals for CI 420 EI	Screw and clamp washer	1 - 4	1 - 4	1 - 2.5	1.4 - 2.3

Auxiliary contacts, load categories: AC-15 and AC-1

Type	Comments	Max. operating current [A]							
		AC-15						AC-1	
		220-230 V	240	380-400 V	415 V	500 V	690 V	40 °C ¹⁾	60 °C ¹⁾
CBC-	For contacts CI 110..CI 420 EI	5.5	5	3	2.5	1.6	1	16	12

¹⁾ 40°C is defined as non-enclosed installation
60°C is defined as enclosed installation

Auxiliary contacts, load categories DC-12, DC-13, DC-14

Type	Comments	Max. operating current [A]														
		DC-12					DC-13					DC-14				
		24 V	48 V	110 V	220 V	440 V	24 V	48 V	110 V	220 V	440 V	24 V	48 V	110 V	220 V	440 V
CBC-	For contacts CI 110...CI 420 EI	16	9	3.5	0.55	0.2	5	2	0.7	0.25	0.12	9	5	2	0.4	0.16

Coils, consumption and operating times

Type	Inrush power		Holding power		Pull-in voltage	Drop-out voltage	Make time	Break time
	a.c.	a.c.	a.c.	a.c.	a.c.	a.c.		
	VA	W	VA	W	V	V	ms	ms
CI 110 - CI 180	380	240	13	6	$(0.85-1.1) \times U_S$	$(0.35-0.65) \times U_S$	20-45	25-110
CI 210EI - CI 300 EI	380	240	13	6	$0.85 \times U_{min}$ $\dots 1.1 \times U_{max}$	$0.3 \dots 0.5$ $\times U_{min}$	20-45	25-110
CI 420 EI	490	270	18	7	$0.85 \times U_{min}$ $\dots 1.1 \times U_{max}$	$0.3 \dots 0.5$ $\times U_{min}$	20-45	25-110

RC element (charge suppressor)

Type	Comments	Overvoltage factor $n = \frac{U_{max}}{U_n}$
RCC	Suitable for contactors CI 110-180	1-2.0
VRC	Suitable for contactors CI 110-180	1-2.5

UL/ CSA specifications

UL/CSA approved loads

Type	Motor load (AC-3) [hp]						Other loads (AC-1) [A]			
	1-phase		3-phase				UL		CSA	
	115 V	230 V	200 V	240 V	460 V	575 V	40 °C ¹⁾	60 °C ¹⁾	40 °C ¹⁾	60 °C ¹⁾
CI 110	10	25	40	40	75	100	178	160	178	160
CI 141	15	30	40	50	100	125	250	220	250	220
CI 180		40	50	60	150	150	250	220	250	220
CI 210 EI		50	60	75	150	200	350	300	350	300
CI 250 EI			75	100	200	250	350	300	350	300
CI 300 EI			100	125	250	300	420	340	420	340
CI 420 EI			150	175	350	400	420	420	420	420

¹⁾ 40 °C is defined as non-enclosed installation
60 °C is defined as enclosed installation

Auxiliary contacts, UL/CSA-approved loads

Type	Comments	Load capacity			
		a.c.		d.c.	
		category	VA	category	W
CBC-	For contactors CI 110..CI 420 EI	A600	720	P600	138

Connections, main contacts

Type	Connection method	Cross section [AWG]	Recommended tightening torque [lb-in]
CI 110	Screw and lug	6 - 2/0	70 - 90
	Terminal block top	6 - 1/0	70 - 90
	Terminal block, bottom	6 - 3/0	70 - 90
CI 141, CI 180	Screw and lug	6 - 250 MCM	90 - 110
	Terminal block top	6 - 1/0	90 - 110
	Terminal block bottom	6 - 250 MCM	90 - 110
CI 210 EI, CI 250 EI	Screw and lug	8 - 600 MCM	180 - 200
	Terminal block top	4 - 600 MCM	180 - 220
CI 300 EI, CI 420 EI	Terminal block bottom	4 - 600 MCM	180 - 220

Dimensions

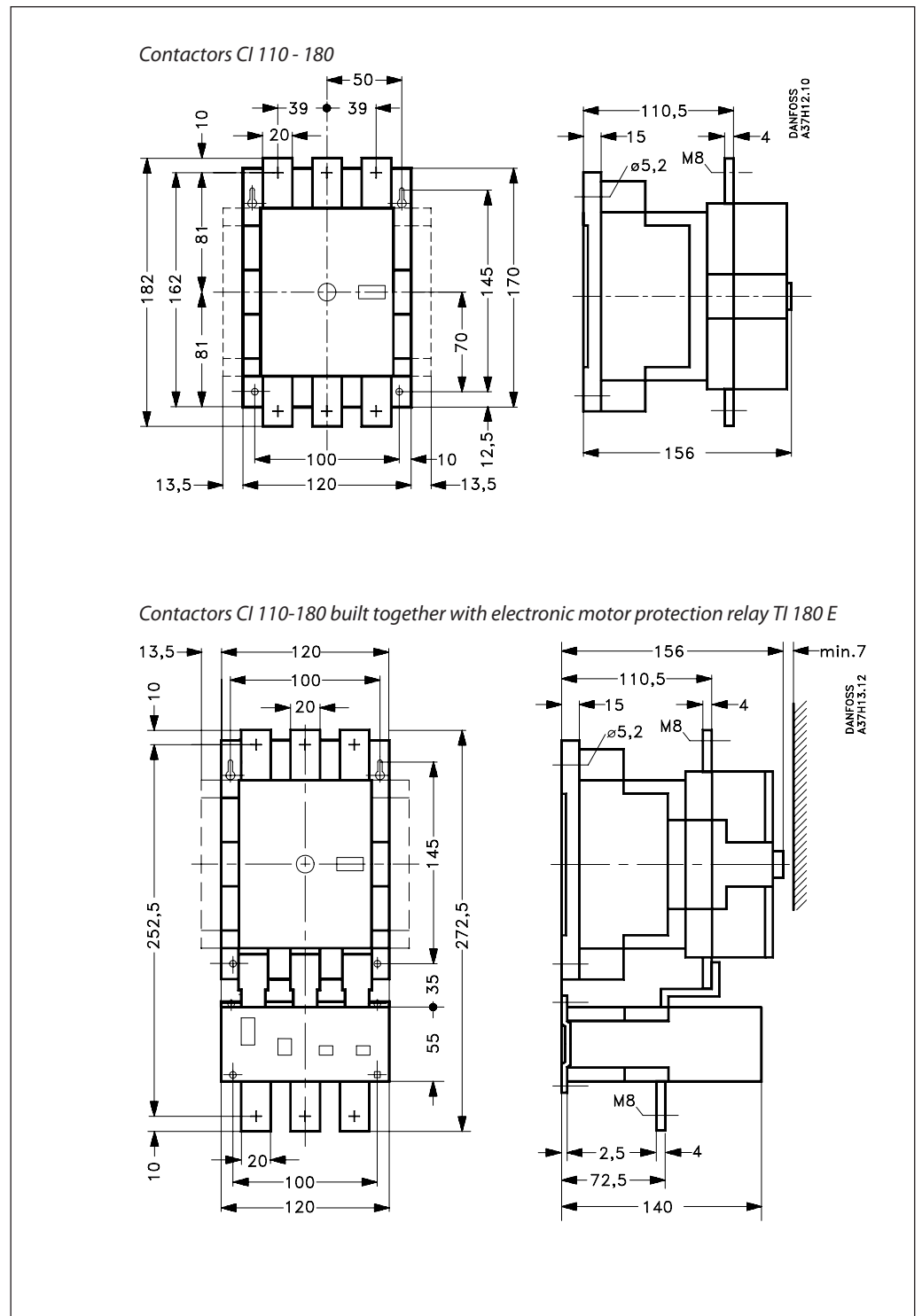

Dimensions (continued)

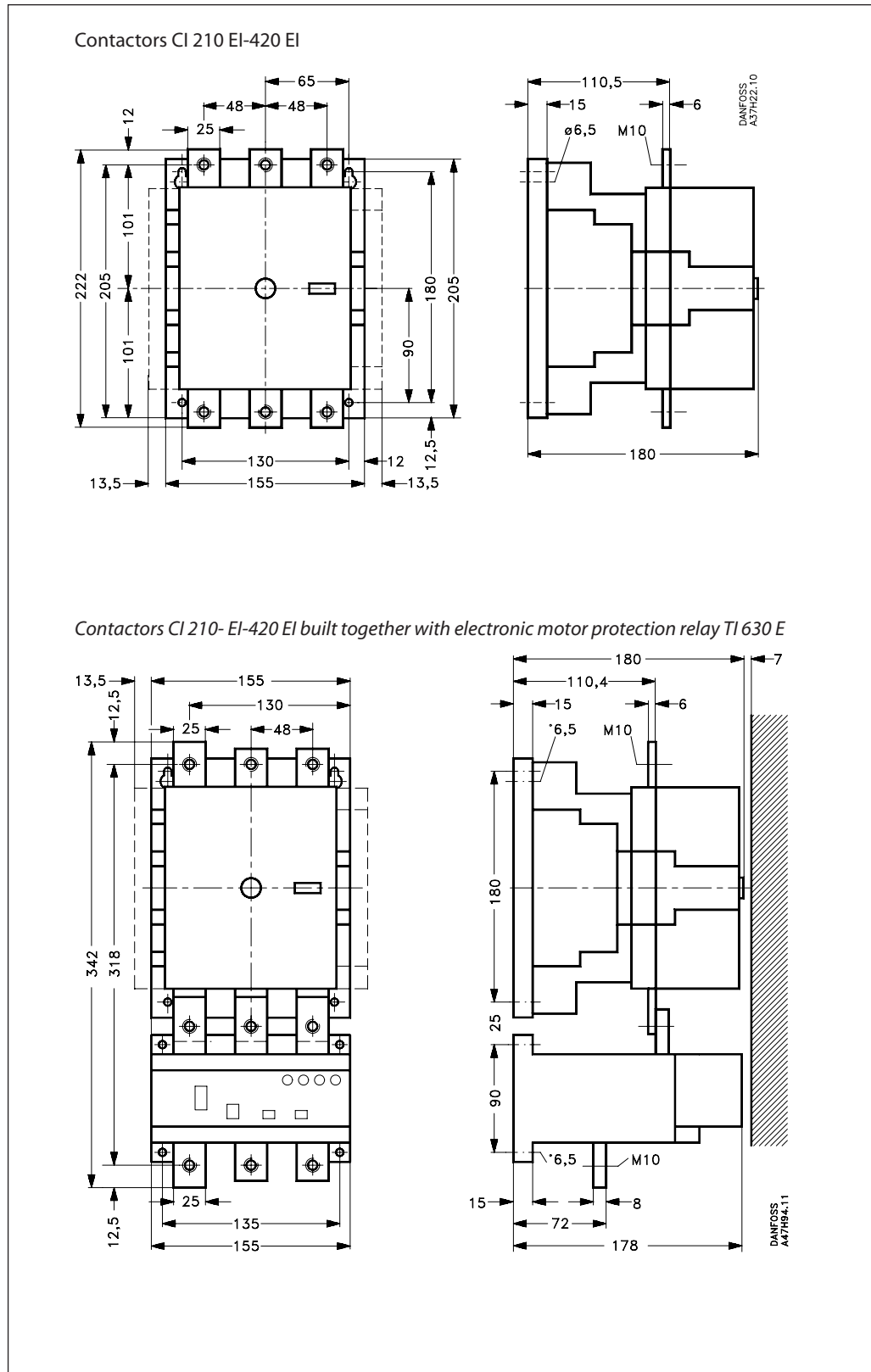

Electronic motor protection relay TI 180 E-630 E

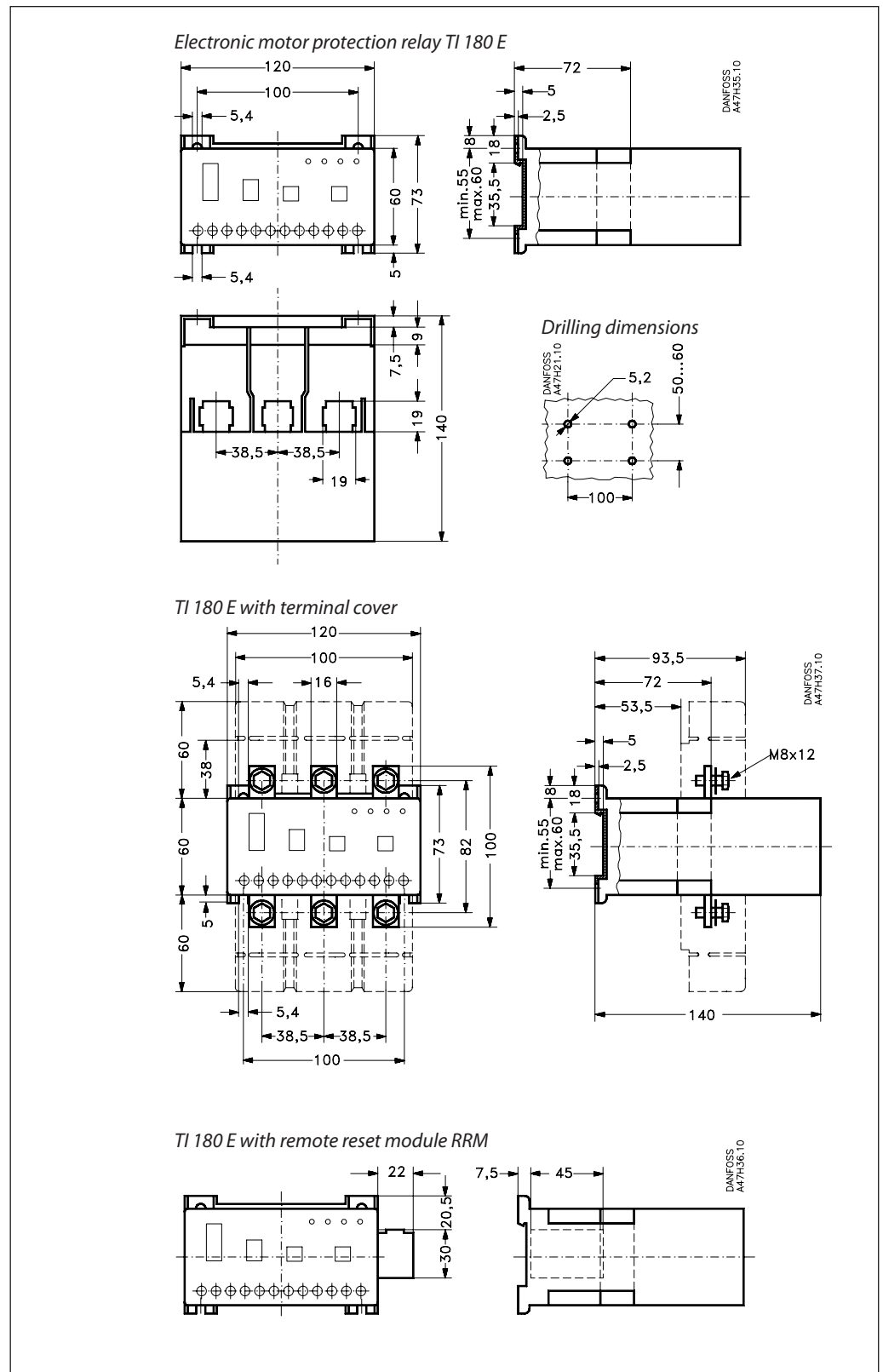

Electronic motor protection relay TI 180 E-630 E

Remote reset module RRM for TI 180 E and TI 630 E mounted on DIN rail adapter

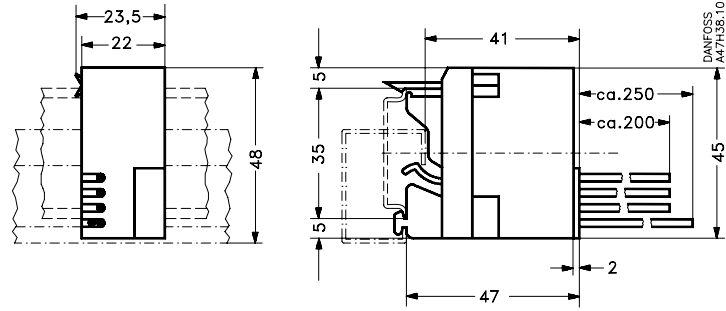

Indication module IMR for TI 180 E and TI 630 E

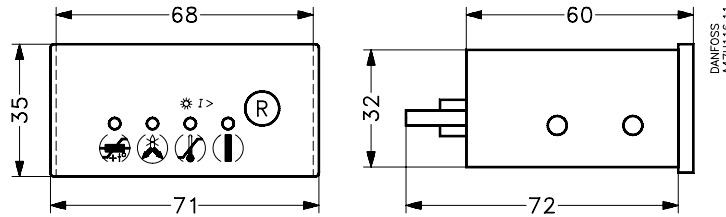

Electronic motor protection relay TI 630 E

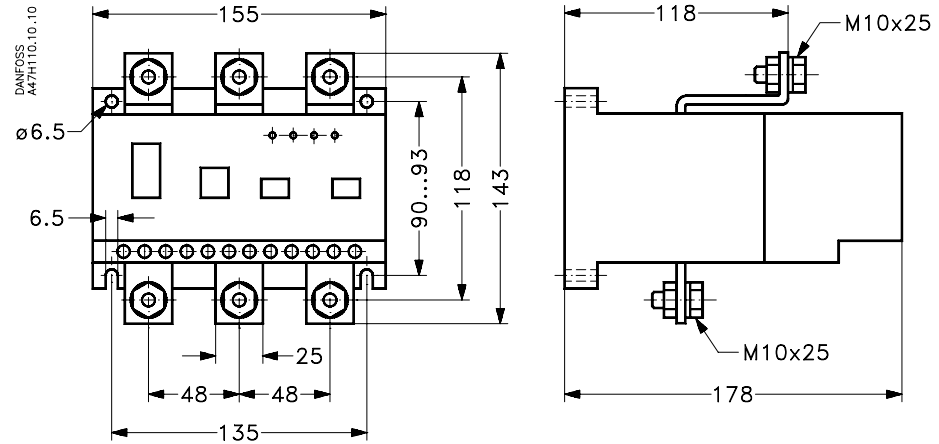

Drilling dimensions

